



“One Company, Many Locations, Global Service”



Zone 1
Zone 2
Zone 21
Zone 22



EC  GLOBAL

Flat Cable Glands

FLAT CABLE GLANDS

DESIGNED AND CERTIFIED FOR GLOBAL SPECIFICATIONS

Eilbeck Cranes provides a termination solution for Explosion Protection Glands used in Hazardous and Industrial environments, both onshore and offshore, above and below ground.

Our cable glands are designed for strict adherence to global specifications of Ex d and Ex e enclosures, for IEC wiring standards, meeting international certification requirements including ATEX and IECEx.

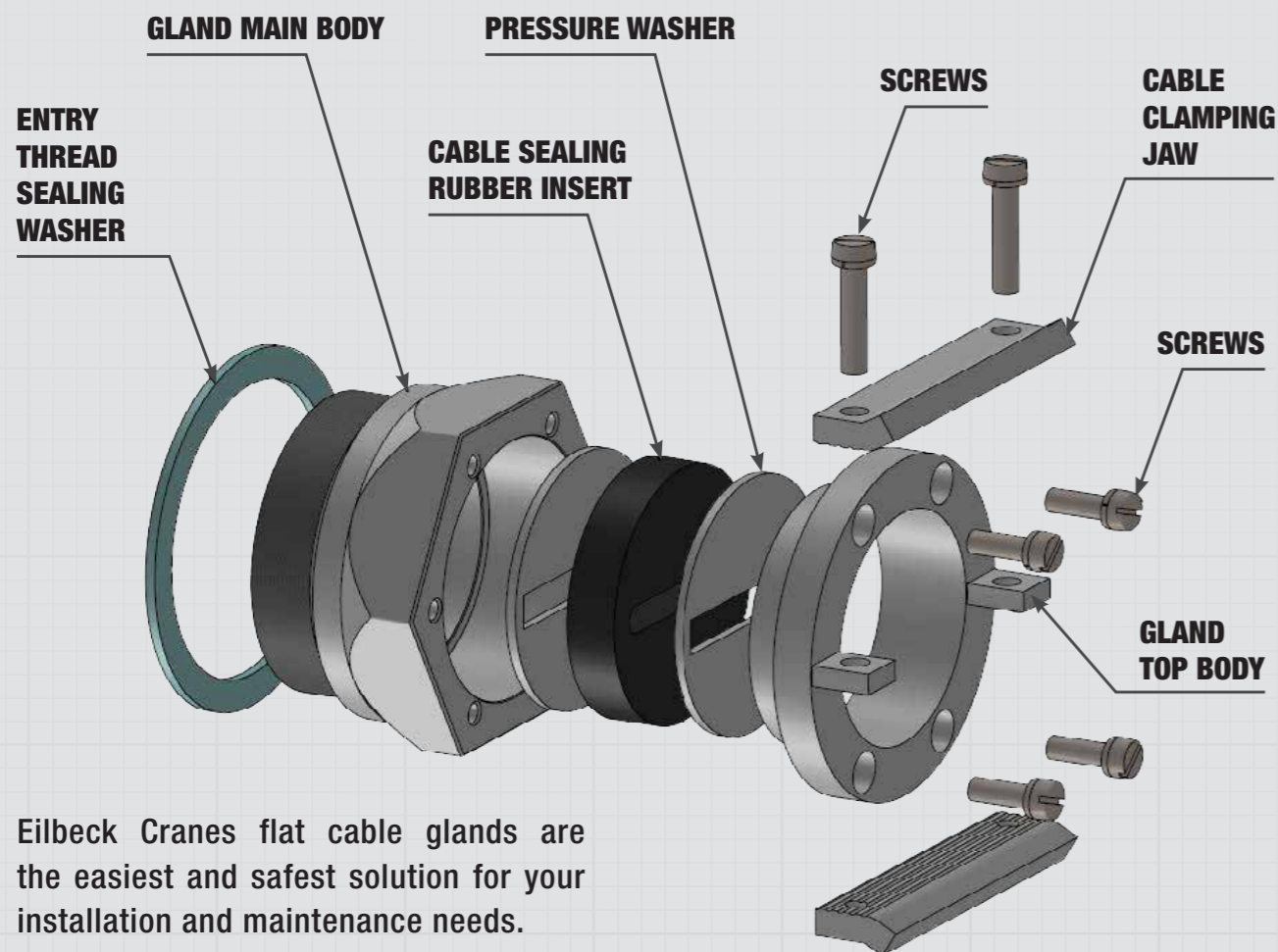

Eilbeck Cranes flat cable glands are the easiest and safest solution for your installation and maintenance needs.

RANGE OF GLANDS

Thread Size	Model Number	Part Number	Cable Width		Cable Height	
			Max	Min	Max	Min
M75	ECE-DMS-500	33ZM64	48.0mm	42.0mm	14.0mm	12.0mm
M75	ECE-DMS-500	41YT29	48.0mm	42.0mm	16.0mm	14.0mm
M75	ECE-DMS-500	28DR91	54.0mm	48.0mm	8.0mm	6.0mm
M75	ECE-DMS-500	95QM47	54.0mm	48.0mm	12.0mm	10.0mm
M75	ECE-DMS-500	28SZ74	54.0mm	48.0mm	14.0mm	12.0mm
M75	ECE-DMS-500	98KQ79	54.0mm	48.0mm	16.0mm	14.0mm
M75	ECE-DMS-500	52EL32	54.0mm	48.0mm	18.0mm	16.0mm
M75	ECE-DMS-500	70RJ74	60.0mm	54.0mm	8.0mm	6.0mm
M75	ECE-DMS-500	10AJ98	60.0mm	54.0mm	10.0mm	8.0mm
M75	ECE-DMS-500	48UZ34	60.0mm	54.0mm	12.0mm	10.0mm
M75	ECE-DMS-500	82LE37	60.0mm	54.0mm	14.0mm	12.0mm
M75	ECE-DMS-500	82ZW50	60.0mm	54.0mm	16.0mm	14.0mm
M75	ECE-DMS-500	80AY96	60.0mm	54.0mm	18.0mm	16.0mm
M75	ECE-DMS-500	34YK95	60.0mm	54.0mm	20.0mm	18.0mm
M75	ECE-DMS-500	35CP37	66.0mm	60.0mm	10.0mm	8.0mm
M75	ECE-DMS-500	35QM22	66.0mm	60.0mm	14.0mm	12.0mm
M75	ECE-DMS-500	17WR38	66.0mm	60.0mm	18.0mm	16.0mm
M75	ECE-DMS-500	28VL32	66.0mm	60.0mm	20.0mm	18.0mm
M75	ECE-DMS-500	65DH50	66.0mm	60.0mm	22.0mm	20.0mm
M63	ECE-DMS-100	84ZZ32	47.5mm	43.5mm	7.2mm	6.0mm
M63	ECE-DMS-100	40GY31	46.0mm	43.0mm	15.5mm	13.5mm
M63	ECE-DMS-100	87WP91	45.0mm	40.0mm	14.5mm	12.5mm
M63	ECE-DMS-100	85XL61	44.0mm	39.6mm	12.9mm	10.9mm
M63	ECE-DMS-100	16CK32	41.5mm	37.9mm	6.5mm	5.0mm
M63	ECE-DMS-100	83DD66	40.0mm	36.0mm	11.5mm	9.5mm
M63	ECE-DMS-100	42BP71	39.5mm	34.5mm	13.5mm	11.5mm
M63	ECE-DMS-100	68DU33	38.3mm	35.0mm	8.5mm	6.5mm
M50	ECE-DMS-200	71XL89	36.9mm	32.3mm	11.5mm	9.5mm
M50	ECE-DMS-200	68UH79	33.9mm	31.0mm	7.8mm	6.6mm
M50	ECE-DMS-200	48RX75	33.1mm	30.0mm	11.0mm	9.9mm
M50	ECE-DMS-200	58HJ45	31.8mm	28.0mm	8.5mm	6.4mm
M50	ECE-DMS-200	64EY89	31.0mm	28.1mm	10.0mm	8.0mm
M50	ECE-DMS-200	21VL32	30.6mm	27.5mm	10.5mm	8.5mm
M50	ECE-DMS-200	68ND13	31.5mm	28.5mm	6.5mm	4.5mm
M40	ECE-DMS-300	87BE27	29.1mm	26.1mm	6.4mm	5.4mm
M40	ECE-DMS-300	24JD90	28.0mm	25.4mm	10.3mm	8.7mm
M40	ECE-DMS-300	12VW31	26.6mm	23.2mm	8.5mm	6.5mm
M40	ECE-DMS-300	35DE83	25.3mm	23.0mm	9.4mm	8.0mm
M40	ECE-DMS-300	20ZT41	24.6mm	22.1mm	6.5mm	4.5mm
M40	ECE-DMS-300	60MY87	24.0mm	21.0mm	9.5mm	7.5mm
M40	ECE-DMS-300	95GC59	23.5mm	20.8mm	8.0mm	6.0mm
M40	ECE-DMS-300	35HF98	22.0mm	19.5mm	6.5mm	4.5mm
M40	ECE-DMS-300	90VB44	20.0mm	17.0mm	8.5mm	6.5mm
M40	ECE-DMS-300	63YY85	20.0mm	17.0mm	6.5mm	4.5mm
M32	ECE-DMS-400	36PB33	22.0mm	19.5mm	6.5mm	4.5mm
M32	ECE-DMS-400	32ZL60	20.7mm	18.7mm	7.8mm	6.6mm
M32	ECE-DMS-400	94PP59	20.0mm	17.0mm	6.5mm	4.5mm
M32	ECE-DMS-400	57XJ28	17.3mm	15.6mm	6.4mm	5.4mm
M32	ECE-DMS-400	63GL74	16.9mm	14.5mm	6.5mm	4.5mm

AVAILABLE SIZES:
M32, M40, M50, M63, M75

HAZARDOUS AREA RATING:
Increased Safety Ex 'e',
Enclosed by 'tb'

TEMPERATURE RATING:
-40°C to +130°C

IECEx CERTIFICATE:
IECEx ExTC 18.0001X

IECEx MARKING:
Ex eb IIC Gb,
Ex tb IIIC Db, IP66

ATEX CERTIFICATE:
TUV 18 ATEX8196X

ATEX MARKING:
II 2 G Ex eb IIC Gb
II 2 D Ex tb IIC Db, IP66



MATERIAL:
BRASS ALLOY

FINISHING:
NICKEL PLATING WITH
25µm THICKNESS

MATERIAL OPTION:
STAINLESS STEEL
AVAILABLE ON REQUEST

Certification

IEC		IECEX		IECEX Certificate of Conformity	
INTERNATIONAL ELECTROTECHNICAL COMMISSION IEC Certification Scheme for Explosive Atmospheres <small>for rules and details of the IECEX Scheme visit www.ieceex.com</small>					
Certificate No.:	IECEX EXTC 18.0001X	Issue No.:	0		
Status:	Current	Page 1 of 3			
Date of Issue:	2018-05-12				
Applicant:	Eilbeck Cranes 6 Moorlands Road Ingleburn, NSW 2565 Australia				
Equipment:	Flat cable gland - M32, M40, M50 and M63				
Optional accessory:					
Type of Protection:	Increased safety 'eb', Protection by Enclosure 'tb'				
Marking:	Ex eb IIC Gb Ex tb IIIC Db IP66				
Approved for issue on behalf of the IECEX Certification Body:	Ajay Maira				
Position:	Certification Authority				
Signature:	<i>Ajay Maira</i>				
(for printed version)					
Date:	2018-05-12				
1. This certificate and schedule may only be reproduced in full. 2. This certificate is not transferable and remains the property of the issuing body. 3. The Status and authenticity of this certificate may be verified by visiting the Official IECEX Website .					
Certificate issued by:					
Ex Testing and Certification Pty Ltd 1/30 Kennington Drive Tomago NSW 2322 Australia					

(1) EU-TYPE EXAMINATION CERTIFICATE		
(2) Equipment and Protective Systems intended for use in Potentially Explosive Atmosphere - Directive 2014/34/EU		
(3) EU-Type Examination Certificate Number	TÜV 18 ATEX 8196 X Issue: 00	
(4) Equipment:	Flat cable gland - M63, M50, M40 and M32	
(5) Manufacturer:	Eilbeck Cranes	
(6) Address:	53 Lancaster St, Ingleburn, NSW 2565 Australia	
(7) This product and any acceptable variation thereto are specified in the schedule to this certificate and the documents therein referred to.		
(8) The TÜV Rheinland Zertifizierungsstelle für Explosionsschutz von TÜV Rheinland Industrie Service GmbH, Notified Body No. 0035 in accordance with Article 21 of the Council Directive 2014/34/EU of 26th February 2014, certifies this product which has been found to comply with the Essential Health and Safety Requirements relating to the design and construction of equipment and protective systems intended for use in potentially explosive atmosphere, given in Annex II to the Directive. The examination and test results are recorded in the confidential report 557/Ex 8196.00/18		
(9) Compliance with the Essential Health and Safety Requirements, with the exception of those listed in the schedule of this certificate, has been assessed by reference to:	EN 60079-0:2012/A11:2013; EN 60079-31:2014; EN 60079-7:2015;	
(10) If the sign "X" is placed after the certificate number, it indicates that the equipment is subject to special conditions for safe use specified in the schedule to this certificate.		
(11) This EU-Type Examination Certificate relates only to the design and specification for construction of the equipment or protective system. It does not cover the process for actual manufacture or supply of the equipment or protective system, for which further requirements of the directive are applicable.		
(12) The marking of the equipment shall include the following:	 II 2 G Ex eb IIC Gb II 2 D Ex tb IIIC Db	
TÜV Rheinland Zertifizierungsstelle für Explosionsschutz		Cologne, 2018-06-11
 Dipl.-Ing. Klaus Peter Graf		
<small>This EU-Type Examination Certificate without signature and stamp shall not be valid. This EU-Type Examination Certificate may be circled only without alteration. Extracts or alterations are subject to approval by the TÜV Rheinland Industrie Service GmbH TÜV Rheinland Group, Am Grauen Stein 51105 Köln Tel: +49 (0) 221 808-0 Fax: +49 (0) 221 808 114</small>		
www.tuv.com		 

THINK

THINK

Address & Contact:

53 Lancaster Street
 Ingleburn NSW 2565
 P: 61 (02) 9618 1904
 E: machining@eilbeckcranes.com
www.eilbeckcranes.com
www.exproofcranes.com

Services Available:

- Technical Support
- Installation and Setup
- Packaging and Transport Costs
- Guaranteed Warranty

Sydney - Heavy Machining / Assy
 41 Broadhurst Road
 Ingleburn NSW 2565
 Phone: 61 (02) 9618 1904
machining@eilbeckcranes.com

Sydney - CNC Machining
 53 Lancaster Street
 Ingleburn NSW 2565
 Phone: 61 (02) 9618 1904
machining@eilbeckcranes.com

Sydney - Manufacturing
 6 Moorlands Road
 Ingleburn NSW 2565
 Phone: 61 (02) 9829 3700
sydney@eilbeckcranes.com

Melbourne - Manufacturing
 321 Doherty's Road
 Truganina VIC 3029
 Phone: 61 (03) 9369 7444
melbourne@eilbeckcranes.com

Perth - Manufacturing
 28 Jackson Street
 Bassendean WA 6054
 Phone: 61 (08) 9279 4800
perth@eilbeckcranes.com

Mackay - Manufacturing
 32 Diesel Drive
 Paget QLD 4740
 Phone: 61 (07) 4998 5599
mackay@eilbeckcranes.com