

EXPLOSION PROTECTED CRANE SYSTEMS

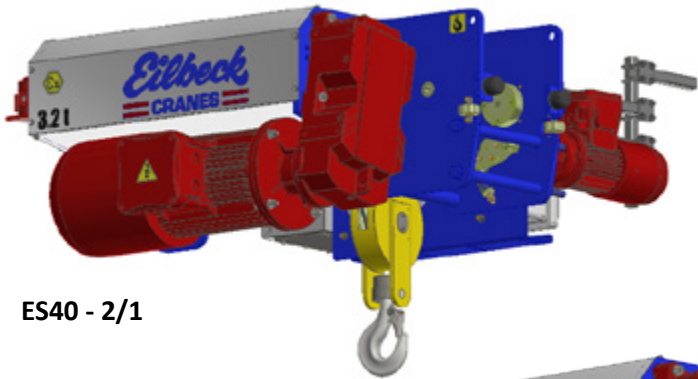

ES40 - 2/1

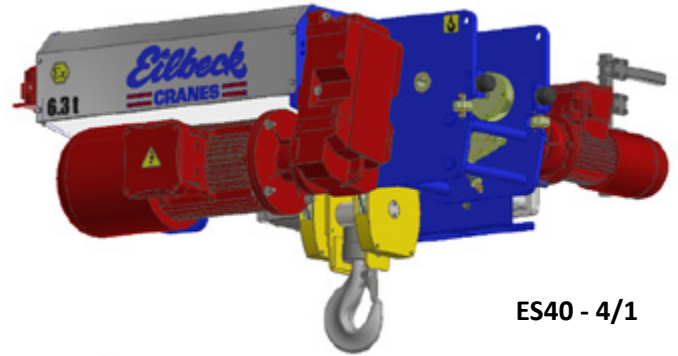

ES40 - 4/1

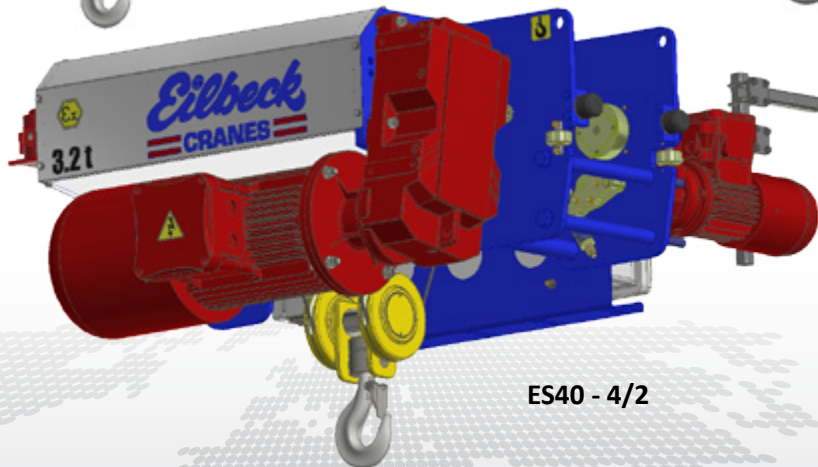

ES40 - 4/2

Reeving	2/1	<input type="checkbox"/>	4/1	<input type="checkbox"/>	4/2	<input type="checkbox"/>
Model Number		Serial Number		
MRC or WLL		Year of Manufacture	2018		

EC  GLOBAL

TECHNICAL DATA - ES 40

INDEX

1.1. General Dimensions - Model ES40	3
1.1.1. Reeving 2.1.....	3
1.1.2. Reeving 4.1.....	3
1.1.3. Reeving 4.2.....	3
1.2. Hoisting Data - Model ES40	4
1.2.1. Reeving 2.1.....	4
1.2.2. Reeving 4.1.....	5
1.2.3. Reeving 4.2.....	6
1.3. Cross Travel Data - Model ES40	7
1.3.1. Reeving 2.1.....	7
1.3.2. Reeving 4.1.....	7
1.3.3. Reeving 4.2.....	7
1.4. Torque Settings	8

1.1. General Dimensions - Model ES40

1.1.1. Reeving 2.1

HOL [m]	LO [mm]	LW [mm]	HS [mm]	FW [mm]	Grooved Length [mm]	Max Mass [kg]	Rope Length [m]
12	1208	850	211	160-600	490	634	28
20	1488	1130	352	160-600	770	378	44
30	1838	1480	528	160-600	1120	734	65

1.1.2. Reeving 4.1

HOL [m]	LO [mm]	LW [mm]	HS [mm]	FW [mm]	Grooved Length [mm]	Max Mass [kg]	Rope Length [m]
6	1208	850	103	160-600	490	717	30
10	1488	1130	176	160-600	770	765	46
15	1838	1480	364	160-600	1120	826	66

1.1.3. Reeving 4.2

HOL [m]	LO [mm]	LW [mm]	HS [mm]	FW [mm]	Grooved Length [mm]	Max Mass [kg]	Rope Length [m]
6	1159	801	636	160-600	210-x2	625	28
10	1379	1021	746	160-600	320x2	659	44
15	1649	1291	881	160-600	465x2	701	64

1.2. Hoisting Data - Model ES40

1.2.1. Reeving 2.1

Load Capacity [t]	Speed (50Hz) [m/min]	Speed (60Hz) [m/min]	Rated Output [Kw]	Current [A]	ED [%]	RPM [rev/min]
1.6	1.3/8	1.6/9.6	0.65/4	5.10/4.7	40	480/2970
1.6	1.7/10	2/12	0.65/4	5.10/4.7	40	480/2970
1.6	2.1/12.6	2.5/15.1	0.65/4	5.10/4.7	40	480/2970
1.6	2.7/16	3.2/19.2	1.1/6.5	6.70/13.2	40	430/2960
2	1.3/8	1.6/9.6	0.65/4	5.10/4.7	40	480/2970
2	1.7/10	2/12	0.65/4	5.10/4.7	40	480/2970
2	2.1/12.6	2.5/15.1	1.1/6.5	6.70/13.2	40	430/2960
2	2.7/16	3.2/19.2	1.1/6.5	6.70/13.2	40	430/2960
2.5	1.3/8	1.6/9.6	0.65/4	5.10/4.7	40	480/2970
2.5	1.7/10	2/12	1.1/6.5	6.70/13.2	40	430/2960
2.5	2.1/12.6	2.5/15.1	1.1/6.5	6.70/13.2	40	430/2960
2.5	2.7/16	3.2/19.2	1.1/6.5	6.70/13.2	40	430/2960
3.2	1.3/8	1.6/9.6	1.1/6.5	6.70/13.2	40	430/2960
3.2	1.7/10	2/12	1.07/10	11.1/20.2	40	485/2960

1.2.2. Reeving 4.1

Load Capacity [t]	Speed (50Hz) [m/min]	Speed (60Hz) [m/min]	Rated Output [Kw]	Current [A]	ED [%]	RPM [rev/min]
3.2	0.7/4	0.8/4.8	0.65 / 4	5.10 / 4.7	40	480 / 2970
3.2	0.8/5	1/6	0.65 / 4	5.10 / 4.7	40	480 / 2970
3.2	1.1/6.3	1.3/7.6	0.65 / 4	5.10 / 4.7	40	480 / 2970
3.2	1.3/8	1.6/9.6	1.1 / 6.5	5.10 / 4.7	40	430 / 2960
4	0.7/4	0.8/4.8	0.65 / 4	5.10 / 4.7	40	480 / 2970
4	0.8/5	1/6	0.65 / 4	5.10 / 4.7	40	480 / 2970
4	1.1/6.3	1.3/7.6	1.1 / 6.5	6.70 / 13.2	40	430 / 2960
4	1.3/8	1.6/9.6	1.1 / 6.5	6.70 / 13.2	40	430 / 2960
5	0.7/4	0.8/4.8	0.65 / 4	5.10 / 4.7	40	480 / 2970
5	0.8/5	1/6	1.1 / 6.5	6.70 / 13.2	40	430 / 2960
5	1.1/6.3	1.3/7.6	1.1 / 6.5	6.70 / 13.2	40	430 / 2960
5	1.3/8	1.6/9.6	1.1 / 6.5	6.70 / 13.2	40	430 / 2960
6.3	0.7/4	0.8/4.8	1.1 / 6.5	6.70 / 13.2	40	430 / 2960
6.3	0.8/5	1/6	1.7/10	11.1 / 20.2	40	485 / 2960

1.2.3. Reeving 4.2

Load Capacity [t]	Speed (50Hz) [m/min]	Speed (60Hz) [m/min]	Rated Output [Kw]	Current [A]	ED [%]	RPM [rev/min]
1.6	1.3/8	1.6/9.6	0.65 / 4	5.10 / 4.7	40	480 / 2970
1.6	1.7/10	2/12	0.65 / 4	5.10 / 4.7	40	480 / 2970
1.6	2.1/12.6	2.5/15.1	0.65 / 4	5.10 / 4.7	40	480 / 2970
1.6	2.7/12.6	3.2/19.2	1.1 / 6.5	6.70 / 13.2	40	430 / 2960
2	1.3/8	1.6/9.6	0.65 / 4	5.10 / 4.7	40	480 / 2970
2	1.7/10	1.6/9.6	0.65 / 4	5.10 / 4.7	40	480 / 2970
2	2.1/12.6	2/12	1.1 / 6.5	6.70 / 13.2	40	430 / 2960
2	2.7/16	2.5/15.1	1.1 / 6.5	6.70 / 13.2	40	430 / 2960
2.5	1.3/8	3.2/19.2	0.65 / 4	5.10 / 4.7	40	480 / 2970
2.5	1.7/10	1.6/9.6	1.1 / 6.5	6.70 / 13.2	40	430 / 2960
2.5	2.1/12.6	2/12	1.1 / 6.5	6.70 / 13.2	40	430 / 2960
2.5	2.7/12.6	2.5/15.1	1.1 / 6.5	6.70 / 13.2	40	430 / 2960
3.2	1.3/8	3.2/19.2	1.1 / 6.5	6.70 / 13.2	40	430 / 2960
3.2	1.7/10	2/12	1.7/10	11.1 / 20.2	40	485 / 2960

1.3. Cross Travel Data - Model ES40

1.3.1. Reaving 2.1

Load Capacity [t]	Speed (50Hz) [m/min]	Speed (60Hz) [m/min]	Rated Output [Kw]	Current [A]	ED [%]	RPM [rev/min]
1.6/2/2.5/3.2	6	7.2	0.12	0.62	40	1380
1.6/2/2.5/3.2	12	14.4	0.18	0.67	40	1340
1.6/2/2.5/3.2	2.5/10	3/12.5	0.3	0.57/1.50	40	670/2850
1.6/2/2.5/3.2	5/20	6/24	0.75	0.57/1.50	40	690/2860

1.3.2. Reaving 4.1

Load Capacity [t]	Speed (50Hz) [m/min]	Speed (60Hz) [m/min]	Rated Output [Kw]	Current [A]	ED [%]	RPM [rev/min]
3.2 / 4 / 5 / 6.3	6	7.2	0.18	0.67	40	1340
3.2 / 4 / 5 / 6.3	12	14.4	0.37	1.1	40	1380
3.2 / 4 / 5 / 6.3	2.5/10	3/12.5	0.3	0.57/1.50	40	670/2850
3.2 / 4 / 5 / 6.3	5/20	6/24	0.75	1.50/2.50	40	690/2860

1.3.3. Reaving 4.2

Load Capacity [t]	Speed (50Hz) [m/min]	Speed (60Hz) [m/min]	Rated Output [Kw]	Current [A]	ED [%]	RPM [rev/min]
1.6 / 2 / 2.5 / 3.2	6	7.2	0.12	0.62	40	1380
1.6 / 2 / 2.5 / 3.2	12	14.4	0.18	0.67	40	1340
1.6 / 2 / 2.5 / 3.2	2.5/10	3/12.5	0.3	0.57/1.50	40	670/2850
1.6 / 2 / 2.5 / 3.2	5/20	6/24	0.3	0.57/1.50	40	670/2850

1.4. Torque Settings

ES Series Hoists Torque Table						
Minimum Tensile Strength MPa	M6 – M16: 800 M20-M30: 830		1040		12.9 Socket Head Cap Screw	
Nominal Size and Thread Pitch	Bolt Torque Specs in Newton Meters - Nm					
	Dry	Lubed	Dry	Lubed	Dry	Lubed
M5 x 0.80	6.1	4.6	8.8	6.7	10.3	7.7
M6 x 1.00	10.4	7.8	15	11.2	17.6	13.1
M7 X 1.00	17.6	131	25.1	18.9	29.4	22
M8 X 1.25	25.4	19.1	37.6	27.3	42.6	32.1
M10 X 1.50	50	38	72	54	84	64
M12 X 1.75	88	66	126	94	146	110
M14 X 2.00	141	106	201	150	235	176
M16 X 2.00	218	164	312	233	365	274
M18 X 2.50	301	226	431	323	504	378
M20 X 2.50	426	319	603	457	712	534
M22 X 2.50	580	435	831	624	971	728
M24 X 3.00	736	552	1052	789	1231	923
M27 X 3.00	1079	809	1544	1158	1805	1353
M30 X 3.50	1463	1097	2092	1570	2446	1834
M33 X 3.50	1990	1493	2849	2137	3328	2497
M36 X 4.00	2557	1918	3659	2744	4276	3208

EC GLOBAL

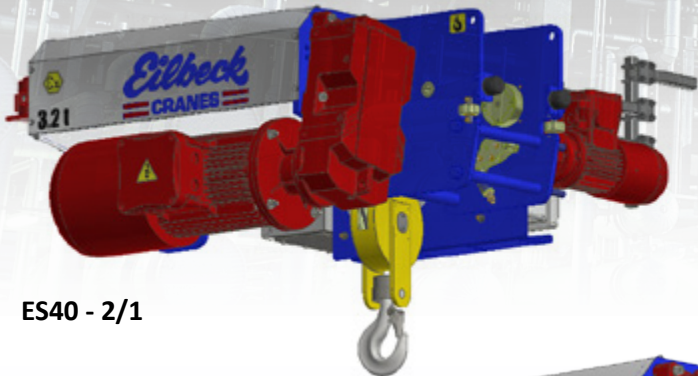

ES40 - 2/1

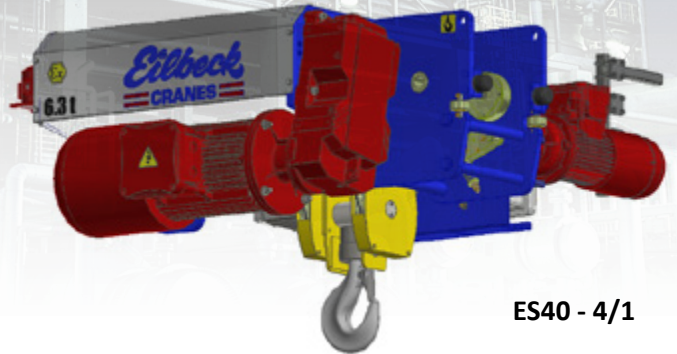

ES40 - 4/1

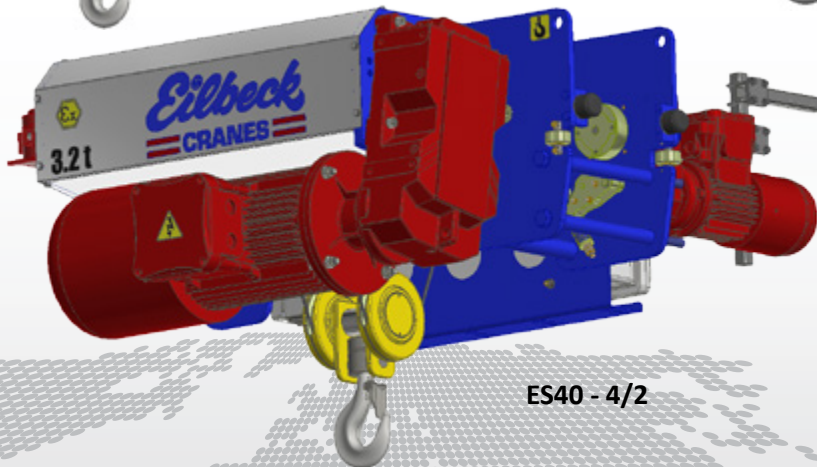

ES40 - 4/2

ATEX 



www.exproofcranes.com

Perth - Manufacturing

28 Jackson Street
Bassendean WA 6054
Phone: 61 (08) 9279 4800
Fax: 61 (08) 9378 3689
perth@eilbeckcranes.com

Perth - Manufacturing

11 Yelland Way
BassendeanWA 6054
Phone: 61 (08) 9379 3724
Fax: 61 (08) 9378 3689
perth@eilbeckcranes.com

Perth - Manufacturing

14 Yelland Way
Bassendean WA 6054
Phone: 61 (08) 9379 3724
Fax: 61 (08) 9378 3689
perth@eilbeckcranes.com

Sydney - Manufacturing

6 Moorlands Road
Ingleburn NSW 2565
Phone: 61 (02) 9829 3700
Fax: 61 (02) 9829 3500
sydney@eilbeckcranes.com

Sydney - Machine Shop

53 Lancaster Street
Ingleburn NSW 2565
Phone: 61 (02) 9618 1904
Fax: 61 (02) 9605 5171
sydney@eilbeckcranes.com

Mackay - Manufacturing

32 Diesel Drive
Paget QLD 4740
Phone: 61 (07) 4998 5599
Fax: 61 (07) 4998 5756
mackay@eilbeckcranes.com